

RECOMMENDED P.C. BOARD HOLE LAYOUT

NO.	PART NAME	DESCRIPTION	PLATING	THICKNESS	QTY
(1)	SHELL	SPCC	NICKEL	0.3MM	1
(2)	HOUSING	Thermoplastic			1
(3)	TERMINAL	BRASS	Duplex Plated over all Nickel	0.25MM	4

SPECIFICATIONS

Current Rating: 1A
 Insulation resistance: 1000 MΩ min.
 Dielectric withstanding voltage: 500VAC/DC
 Operating Temperature: -45°C to 105°C

HOW TO ORDER

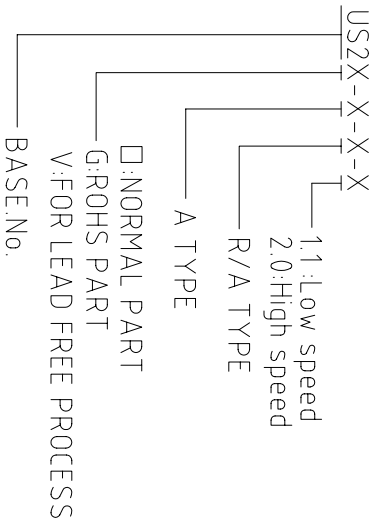

LONG CHU ELECTRONICS CO. LTD
龍竹企業股份有限公司

DESCRIPTION:

USB A TYPE R/S SOCKET 2.0 REV

REV.	DESCRIPTION	DATE	DR.	CHK.	RE.	APP.	MATERIAL	UNIT
B	PART NO. SYSTEM CHANGE	09/18/06*	KELLY				SEE NOTE	MM
A	NEW RELEASE	12/20/05*						
REV.	DESCRIPTION	DATE	DR.	CHK.	RE.	APP.	MATERIAL	UNIT

GENERAL TOLERANCE	SIZE	P/N:
0. ±.50	A4	US2-A-R-2.0
0.0 ±.30	SCALE	REV. B
0.00 ±.20	--	SHEET NO. 40482A